

SMART Board® GX series

SBID-GX165

SBID-GX175

SBID-GX186



DISPLAY

Screen sizes (diagonal)	65", 75", 86"
Backlight	LED
Aspect ratio	16:9
Maximum display resolution	4K UHD (3840 × 2160)
Refresh rate	60 Hz
Lifespan	≥ 50,000 hours
Brightness (maximum)	≥ 400 cd/m ²
Contrast ratio	1200:1
Response time	≤ 8 ms
Viewing angle	178°
Glass	Fully heat-tempered, anti-glare
Glass thickness	4 mm
Frame color	Black
Convenience buttons	Power, home, volume, settings / freeze frame, back
Sensors	Ambient light, infrared
Audio	2 integrated 15 W speakers

INTERACTIVE EXPERIENCE

Touch technology	Advanced infrared
Touch features	Object Awareness™ ¹ Simultaneous Tool Differentiation™ ² Silktouch™
Typical response time	≤ 8 ms
Frame rate	≥ 110 Hz
Accuracy	±1 mm (over 90% area)
Minimum object size	2.0 mm
Multitouch capabilities	20 – Windows® and Mac 10 – Chrome OS™
Tools included	Pens (×2)
Tool holders	Magnetic, frame-mounted

SOFTWARE

SMART Notebook® basic	Included
SMART Ink® and SMART Product Drivers	Included
SMART Remote Management	Optional
SMART Learning Suite	Optional

smarttech.com
smarttech.com/contact

© 2021 SMART Technologies ULC. All rights reserved. SMART Board, SMART Notebook, SMART Ink, Simultaneous Tool Differentiation, Object Awareness, Silktouch, smarttech, the SMART logo and all SMART taglines are trademarks or registered trademarks of SMART Technologies ULC in the U.S. and/or other countries. The Bluetooth word mark is owned by the Bluetooth SIG, Inc. and any use of such marks by SMART Technologies ULC is under license. The Adopted Trademarks HDMI, HDMI High-Definition Multimedia Interface, and the HDMI Logo are trademarks or registered trademarks of HDMI Licensing Administrator, Inc. in the United States and other countries. All other third-party product and company names may be trademarks of their respective owners. This product and/or use thereof is covered by one or more of the following U.S. patents: www.smarttech.com/patents. Models and specifications may vary by region. Please contact your local representative for details. Contents are subject to change without notice. July 22, 2021.

¹When connected to a computer with SMART Product Drivers

²A connected computer with SMART Product Drivers is required. Only supported in SMART Notebook and SMART Ink.

BUILT-IN ANDROID™ EXPERIENCE

Operating system	Android version 8.0
Memory	3 GB DDR
Storage	32 GB
CPU	Dual Core A73 + Dual Core A53
GPU	Dual Core Mali G51
Digital whiteboard	✓
Web browser	✓
Screen sharing	✓
Other features	Input select File manager Overlay Interactive widgets App library
WPS Office	✓
Ability to run third-party applications	✓
Cloud storage access	✓
Languages supported	Arabic, Chinese (Simplified), Chinese (Traditional), Czech, Danish, Dutch, English, Finnish, French, German, Greek, Italian, Japanese, Korean, Lithuanian, Norwegian, Polish, Portuguese, Romanian, Russian, Spanish, Swedish, Turkish
Updates	Over-the-air (OTA)

PC COMPUTING

OPS support	✓
OPS-C support	✓
PC module power supported OPS	60 W
Optional computing modules	SMART OPS PC with Windows 10 Pro SMART Chromebox

INPUTS

	Front	Back
OPS PC accessory slot (60 W devices)	–	1
HDMI® 2.0 with HDCP 1.4 and HDCP 2.2 support	1	2
Display Port 1.2	–	1
VGA video	–	1
YPbPr video 3.5 mm	–	1
AV 3.5 mm (composite video)	–	1
Stereo 3.5 mm	–	1
RS-232 room control (DB-9 connector)	–	1
RJ45 Ethernet (passthrough)	–	2
USB Type-C 4K @ 60Hz Display Port alternate mode, touch, and digital audio; 15 W power delivery	1	–
USB 2.0 Type-A	1	2
USB 2.0 Type-B	1	1
USB 3.0 Type-A	1	–

OUTPUTS

	Front	Back
AV 3.5 mm (composite video)	–	1
Audio S/PDIF	–	1
Stereo 3.5 mm	–	1

INCLUDED CABLES AND ACCESSORIES

	Qty
Country-specific power cable	1
16' 5" (5 m) USB A/B cable	1
Pens	2
External dual-band 2.4 and 5 GHz antennas (2 Wi-Fi, 1 access point)	3
Remote control	1
AAA batteries	2
Illustrated installation instructions	1
Important information document	1

CONNECTIVITY

Wired	RJ45 (×2) 100baseT
Wi-Fi	IEEE 802.11 a/b/g/n/ac with 2 × 2 MIMO (both 2.4 and 5 GHz bands) supporting WEP, WPA, WPA2 PSK, and 802.1X EAP authentication protocols Wi-Fi access point
Bluetooth	4.2 dual mode

STORAGE AND OPERATING REQUIREMENTS

Power requirements	100V to 240V AC, 50 Hz to 60 Hz
Operating temperature	32–104°F (0–40°C)
Storage temperature	14–140°F (-10–60°C)
Humidity	20–80% relative humidity, non-condensing

POWER CONSUMPTION

Typical	65": 117 W 75": 157 W 86": 175 W
Standby	< 0.5 W
Off	0 W

CERTIFICATION AND COMPLIANCE³

US / Canada	UL, FCC, ISED, TSCA, CONEG Packaging, Proposition 65
EU / EEA / EFTA / UK	CE, UKCA, LVD, CB, EMC, RED, REACH, RoHS, Battery, WEEE, Packaging, POP, Ecodesign
Australia / New Zealand	RCM
Performance standards	ENERGY STAR®, HDMI

PURCHASING INFORMATION

Order number: SBID-GX165	SMART Board GX065 interactive display with embedded OS and education software
Order number: SBID-GX175	SMART Board GX075 interactive display with embedded OS and education software
Order number: SBID-GX186	SMART Board GX086 interactive display with embedded OS and education software
Optional accessories	See smarttech.com/accessories

WARRANTY

SMART limited equipment warranty	Includes advanced hardware replacement and access to onsite support. Terms and conditions vary by region. Contact your local reseller or distributor for information and visit smarttech.com/warranty .
---	--

CABLE REQUIREMENTS

HDMI	Certified premium high speed HDMI (18 Gbps) Maximum length: 23' (7 m)
USB 2.0	USB 2.0 certified Hi-Speed (480 Mbps) support Maximum length: 16' (5 m)
USB 3.0	USB 3.0 certified SuperSpeed (5 Gbps) support Maximum length: 9' (3 m)
USB Type-C	USB 3.2 Gen 1 certified SuperSpeed (5 Gbps) support Maximum length: 6' (2 m)
More information	See smarttech.com/kb/171744

³Product availability may vary by region.

This product has received additional certifications not listed here.

INSTALLATION, DIMENSIONS, AND WEIGHTS

NOTES

- All dimensions $\pm 1/8"$ (0.3 cm). All weights ± 2 lb. (0.9 kg).
- Product ships upright.

SBID-GX165

Dimensions

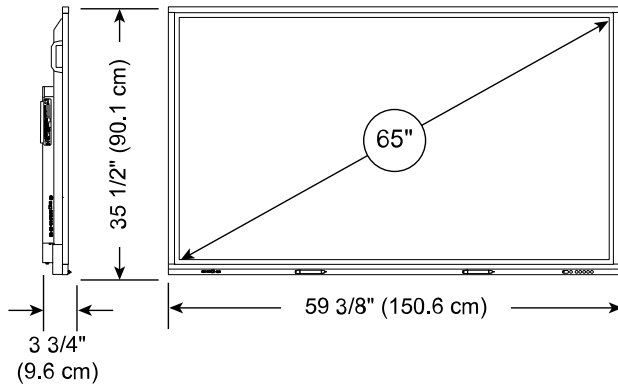

Weight

92 lb. (42 kg)

Shipping dimensions (including pallet)

66 3/8" \times 45 5/8" \times 9 1/4"
(168.5 cm \times 115.9 cm \times 23.5 cm)

Shipping weight

139 lb. (63 kg)

VESA mount

M8, 600 \times 400 mm

Handles

2

SBID-GX175

Dimensions

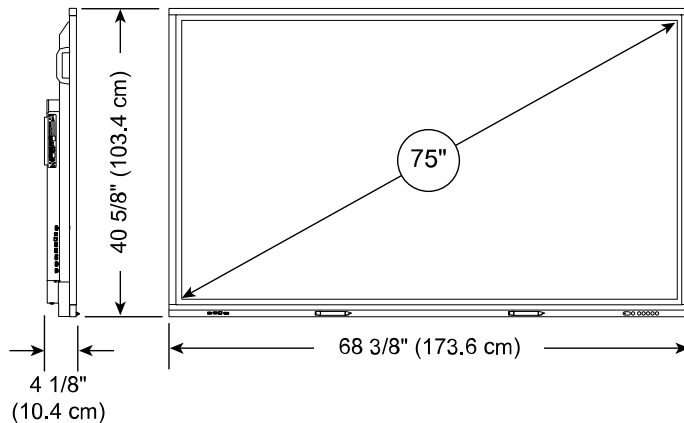

Weight

127 lb. (58 kg)

Shipping dimensions (including pallet)

75 1/4" \times 50 1/8" \times 10 1/4"
(191 cm \times 127.4 cm \times 26 cm)

Shipping weight

181 lb. (82 kg)

VESA mount

M8, 600 \times 400 mm

Handles

2

SBID-GX186

Dimensions

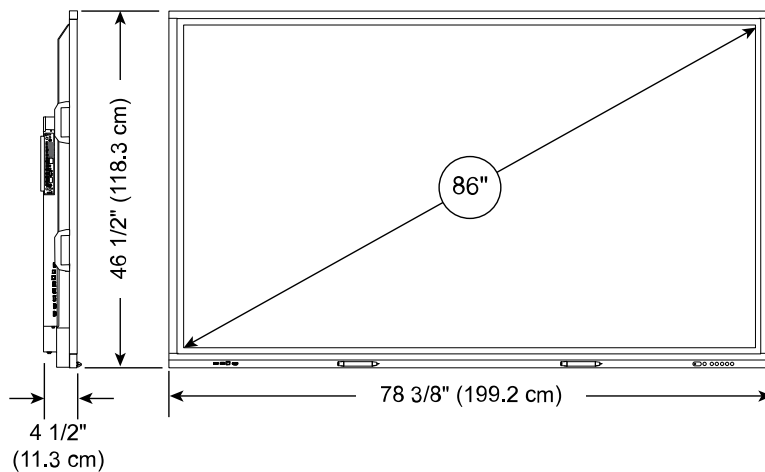

Weight

169 lb. (77 kg)

Shipping dimensions (including pallet)

85 1/4" \times 57 1/4" \times 11 5/8"
(216.5 cm \times 145.4 cm \times 29.5 cm)

Shipping weight

236 lb. (107 kg)

VESA mount

M8, 700 \times 400 mm

Handles

4